

SM4GGC Stig Larsson stig.ake.larsson@gmail.com www.sm4ggc.se



Agenda i dag

- EME idag på 2m, 70cm och 23 cm
- Meteoritscatter
- Aurora
- Optimering vid montering av yagiantenner för olika band i samma mast



EME historia

- 1946 gjordes de första EME experimenten av US Mil. Med 3 KW på 111,5 MHz till en dipolmatta med 24 dBd lyckades man höra sina eko. Experimenten utfördes av W3IYF och W2OQU
- 1953 kom första EME QSO av radioamatörer som utfördes på 144 MHz mellan W4AO och W3GKP
- 1964 första EME QSO EU-US OH1NL och W6DNG
- 1965 SM6CSO 8x13 el har QSO med KP4BPZ (Arecibo dish 300 m) på 70 cm
- 1968 SM7BAE 160 el och 1300W har QSO med K6MYC och ZL1AZR på 144 MHz.

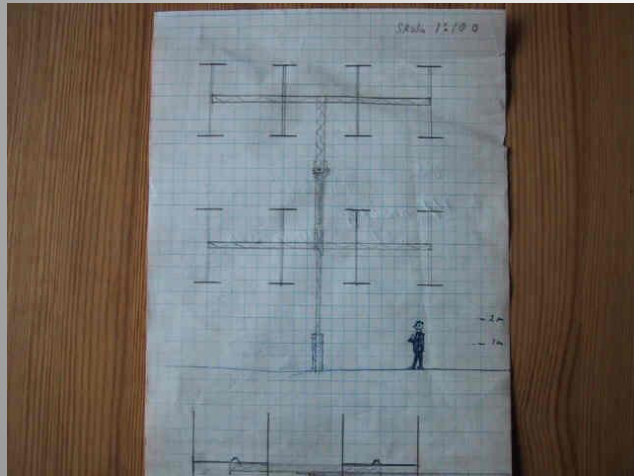

Originalritning från 1967. 16 st 10 element Yagi antenner tillverkades av Yngve SM7BCX och monterades upp hos SM7BAE i Djurslöv.

- ***Avstånd till månen***
 - *Pergiee 356.400 Km*
 - *Apogiee 406.700 Km*
- ***Eko delay ca: 2,4 sec***
- ***93% av signalen absorberas av Månen***
- ***Månen är 1 grad sedd från jorden***

”Svårigheter” vid EME QSO

Polarisations offset mellan två stationer

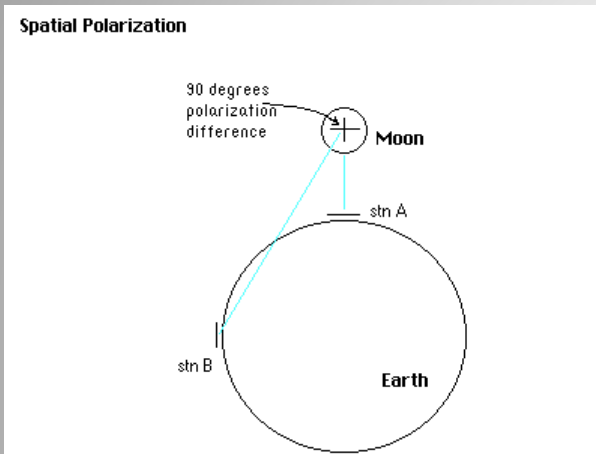

Fraday Rotation

Polarisationsrotation på grund av jordens jonosfär och magnetfält Gör att polarisationen förändras över tiden

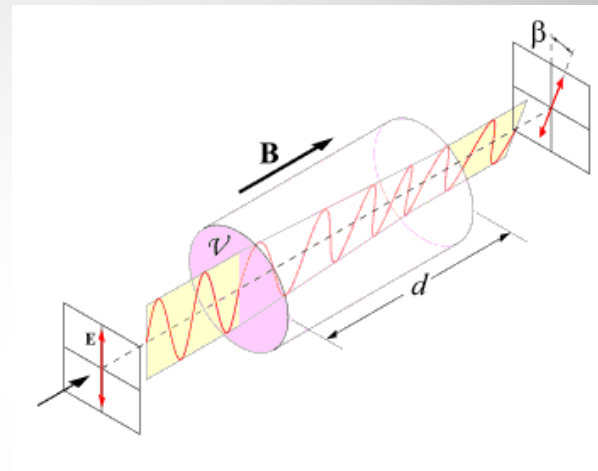

Libration Fading

Signal fading orsakad av måntans ojämnheter

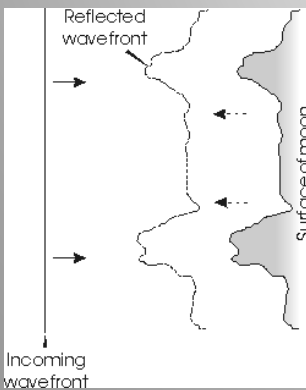

Kosmiskt brus och solbrus

När månen har en brusig bakgrund, vintergatans centrum bakom ger högre brusnivå
När Månen och Solen är nära (nymåne) mycket brus

QRM QRN

Markbrus med störningar från allahanda utrustningar i närområdet
Avtar med stigande frekvens

1 måned med månen

<https://www.mmmonvhf.de/eme.php>

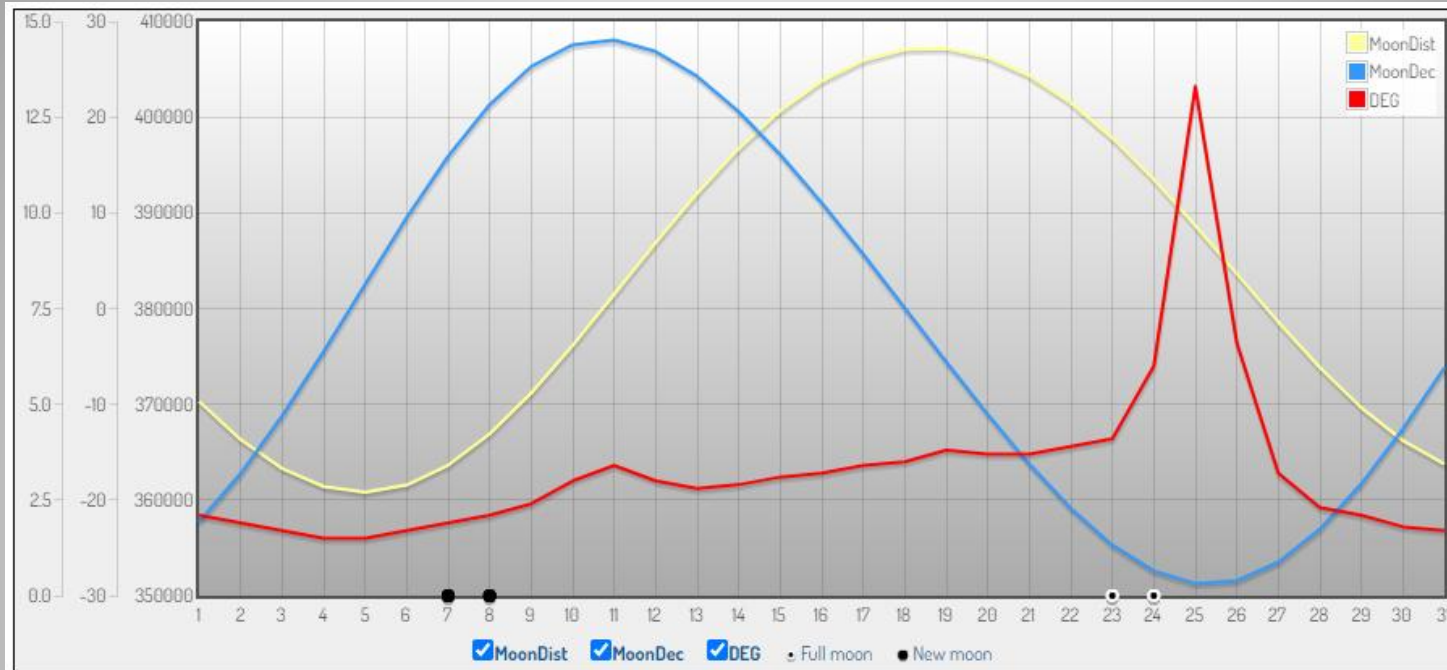

May 2024 Go

Background information:

Moon distance [km]: Earth-Moon distance. Mean distance is 384400 km. Minimum during perigee 356400 km. Maximum during apogee 406700 km. This translates to as much as 2.25dB difference in pathloss from apogee to perigee.

Moon declination [deg]: Moon declination in degrees north (+) and south (-) of the equator. Max declination up to 28.7 degrees.

Degradation [dB]: Degradation in EME signal-to-noise, calculated as: $Tsky [K] / (TskyMin [K] + Tsys [K]) + RangeFactor [dB]$

Calculation assumptions for 144MHz: TskyMin = 200 K, Tsys = 80 K, Observer Position = Central Europe, Time = 12:00 UTC. Tsky data interpolated from EME Handbook 2010 / WSJT 7.03 source data by K1JT.

Conditions summary: Conditions are summarized on basis of the degradation. Be aware that this is only a theoretical approach and the real conditions may vary due to local or ionospheric changes. In general this info is only meant to show the current astronomical situation and to indicate a global trend. Within a day of New Moon (NM), high sun noise can make conditions 'Very Poor' regardless of the DEG. The conditions are classified i.a.w. following DEG [dB]:

- < 1.5 => Excellent
- > 1.5 and <= 2.5 => Good
- > 2.5 and <= 4.0 => Fair
- > 4.0 and <= 5.5 => Poor
- > 5.5 => Very Poor

VK3UM Background Sky Temperature

<https://www.vk5dj.com/doug.html>

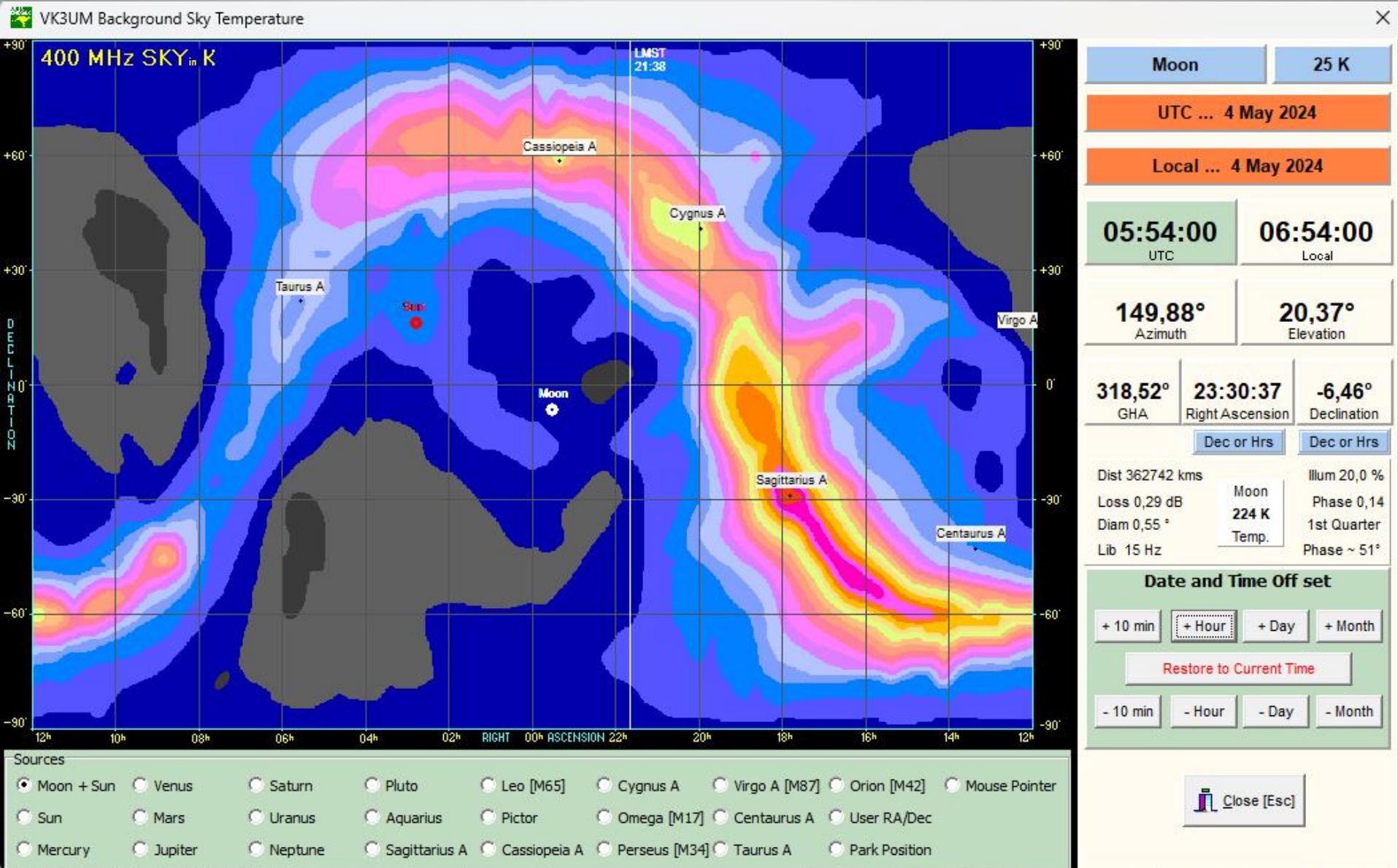

Översikt av frekvensband till EME

- ❑ 50MHz: Inte så vanligt: Kräver oftast stora antenner, massor av QRN

Efektbegränsning i SM till 200W

Digital mode: 100% Q65A

- ❑ 144MHz: Mest populära bandet, massor av stationer

Ett par 10-16 el yagi och 500-1000W räcker långt. Lokal störnivå kan vara ett problem. Låg eller obefintlig aktivitet på CW.

Digital mode: mestadels JT65B och en och annan Q65A

- ❑ 432MHz: Färre stationer. 4 yagis är bra. 400W+ en tillgång

Digital mode: 100% Q65B

- ❑ 1296MHz: Många stationer QRV. En 3 m parabol och 200W+ en bra start

God aktivitet på CW. **Osäkerhet om bandets framtid efter WRC23**

Digital mode: 100% Q65C

Osäkerhet om 23 cm bandets framtid efter WRC23

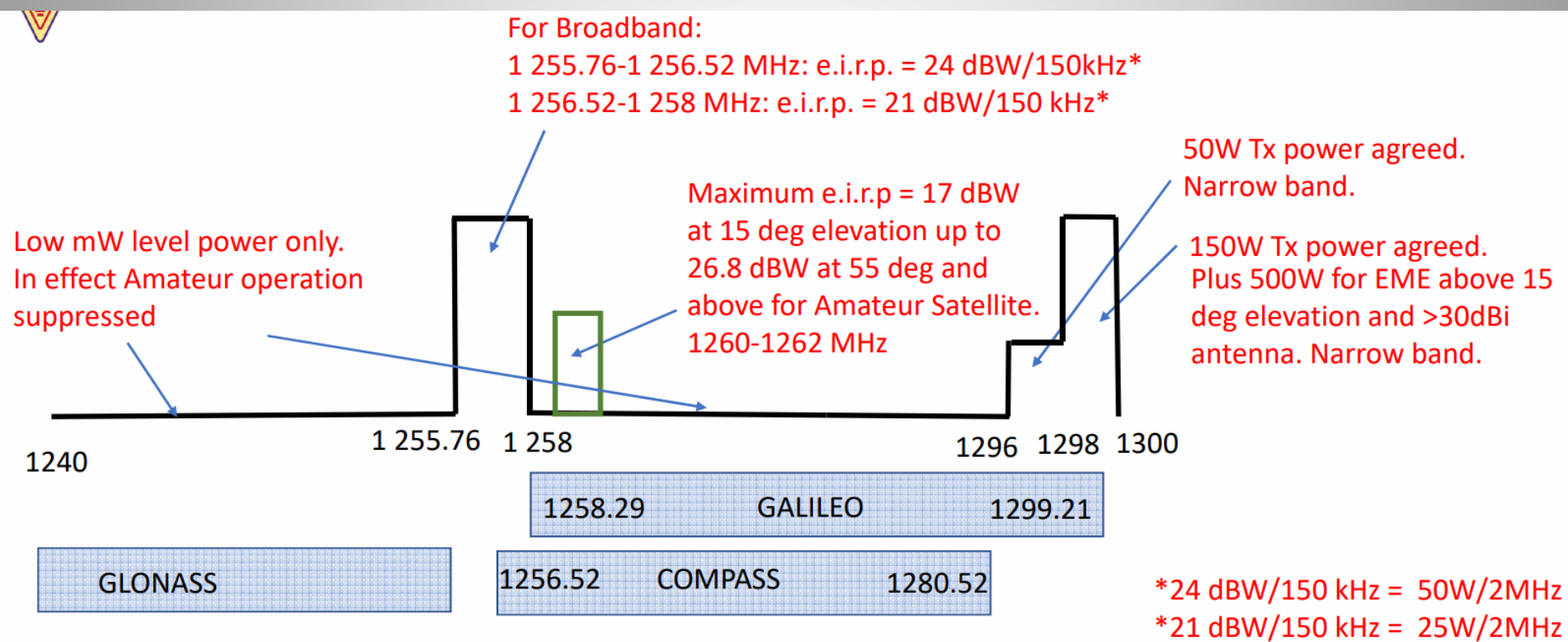

JT65 VS Q65

JT65

- Avkodar signaler typiskt **-25 till -30 dB** under brusnivån med felrättningstabell för mode (JT65)

Utan felrättningstabell påslagen ca **-22 till -24 dB** (JT65)

- **Deep Search tabell**, felrättning mot lista på kända EME stationer (Call3 list endast JT65)

Q65 60 sec

Avkodar signaler **-27.6 dB** under brusnivån. Med AP decoding **-30.2 dB**

”Q65-avkodaren utnyttjar a priori-information (AP), till exempel kodade former av ens egen anropssignal och meddelandeordet CQ”

WSJT-X v2.6.1 by K1JT et al.

File Configurations View Mode Decode Save Tools Help

Single-Period Decodes

UTC	dB	DT	Freq	Message
1151	-21	2.8	1927	GD0TEP GW4ZHI R-16 q0
1152	-13	2.9	1910	GW4ZHI GD0TEP RR73 q0
1154	-15	2.6	1903	GW4ZHI GD0TEP RRR q0

Average Decodes

UTC	dB	DT	Freq	Message
1151	-21	2.8	1927	GD0TEP GW4ZHI R-16 q0
1152	-13	2.9	1910	GW4ZHI GD0TEP RR73 q0

Log QSO Stop Monitor Erase Clear Avg Decode Enable Tx Halt Tx Tune Menu

70cm **432,076 000** Tx even/1st Tx 1500 Hz F Tol 100 Submode B

H DX Call OH3AWW DX Grid KP11VJ Rx 1914 Hz Max Drift

FT8 Az: 65 609 km Report -15

FT4 Lookup Add T/R 60 s

MSK **2024 mar 16 11:56:23** Sh Auto Seq CQ: None Tx6

Q65 JT65

Receiving Q65 Q65-60B 0 1 23/60

Generate Std Msgs

Next	Now	Pwr
OH3AWW SM4GGC JO69	<input type="radio"/>	Tx 1
OH3AWW SM4GGC -15	<input type="radio"/>	Tx 2
OH3AWW SM4GGC R-15	<input type="radio"/>	Tx 3
OH3AWW SM4GGC RR73	<input type="radio"/>	Tx 4
OH3AWW SM4GGC 73	<input type="radio"/>	Tx 5
CQ SM4GGC JO69	<input checked="" type="radio"/>	Tx 6

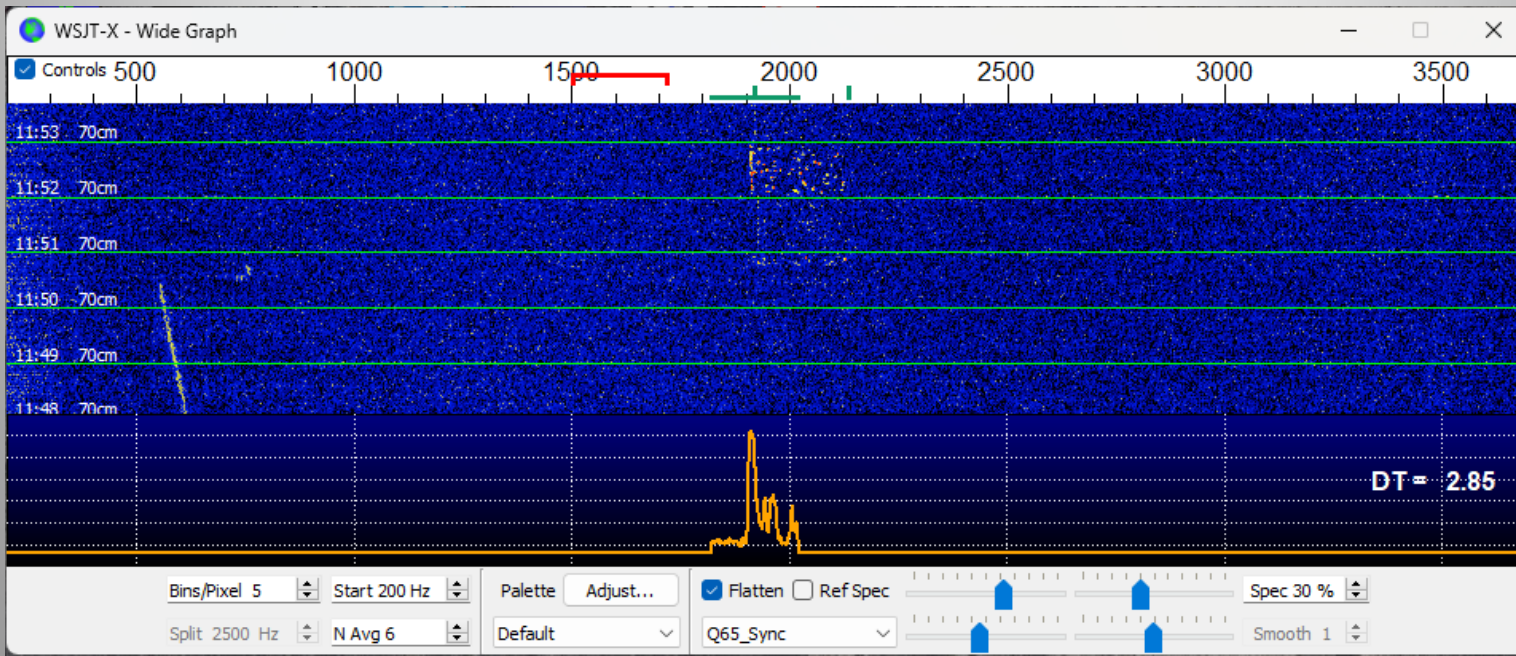

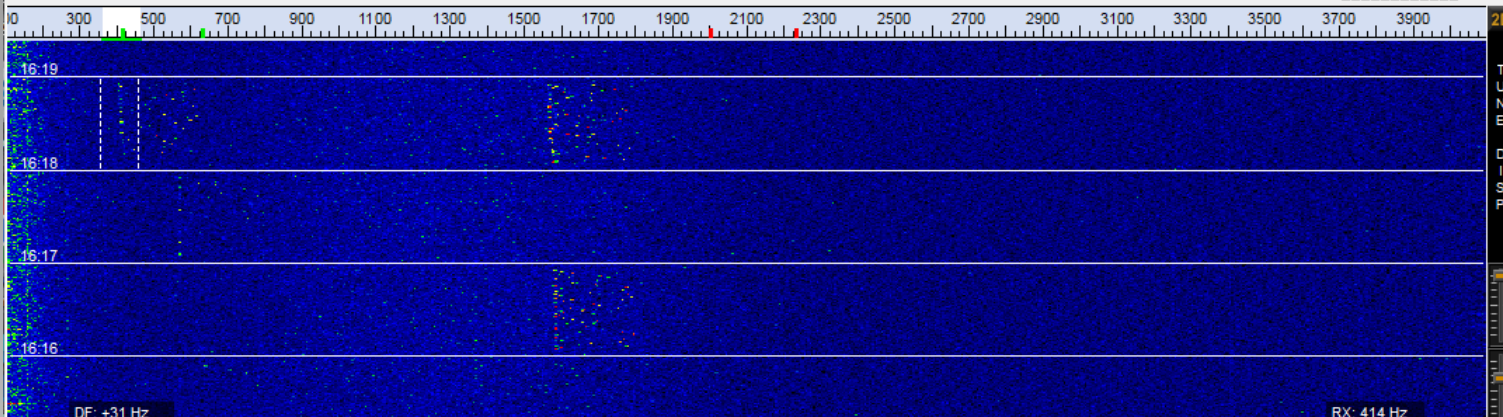

Speed 6 Start 100 Hz BW 4000 Hz FD AF SAVE THIS SAVE PREVIOUS

Q65B Auto Dec RT Dec DECODE RECEIVE Txing: dB -40 -30 -20 -10 0 +10 +20 dB

Time	dB	DT	Message 1 / 3.1s	Freq	Time	dB	DT	RX Frequency Message	Freq
134300	-21	2.6	JO4KVP PA2V JO22	1703	161200	-13	2.6	W4HTB PA2V -31	1595
134500	-19	2.6	JO4KVP PA2V R-23	1697	161400	-13	2.6	W4HTB PA2V -31	1587
134700	-20	2.6	JO4KVP PA2V 73	1688	161800	-13	2.5	W4HTB PA2V -31	1565
135300	-25	2.6	JO4KVP GD0TEP 73	1875					
161000	-13	2.6	W4HTB PA2V -31	1600					
161200	-13	2.6	W4HTB PA2V -31	1595					
161400	-13	2.6	W4HTB PA2V -31	1587					
161400	-13	2.6	W4HTB PA2V -31	1587					
161600	-13	2.6	W4HTB PA2V -31	1578					
161700	-20	2.6	CQ GD0TEP IO74	562					
161800	-13	2.5	W4HTB PA2V -31	1565					

MONITOR STOP MONITOR CLR MSG CLR RX FREQ MSG CLEAR A/G 100 | 95 RESET QSO STOP TX TUNE

SM4GGC JO69 USB 432.077.000 (F)

ADD TO LOG TO RADIO: SM5EPC RX RPT: 59

LOCATOR: JP90CE DB:JP90CE LOOKUP ADD

HotA: 91° Azimuth: 70° Elevation: 18° Dist: 278 km

MONITOR R1: [] R2: []

16 Mar 2024 16:19:22

Queue - N/A © SN: 1193

DF Tol def=1000 +/- 50 Hz

LTR TX = RX TX RPT: 59

ASed TX/RX 60 s QRG: 325

RXS TX FIRST TX SECOND

GEN MSG AUTO IS OFF

RX +20

- SM5EPC SM4GGC JO69
- <SM5EPC> <SM4GGC> 591193 JO69RK
- <SM5EPC> <SM4GGC> R 591193 JO69RK
- SM5EPC SM4GGC RR73
- SM5EPC SM4GGC 73
- CQ TEST SM4GGC JO69**
- SM4GGC QSOB4

Tx1 TX MAX

Tx2

Tx3

Tx4

Tx5

Tx6

Tx7 MIN

(144MHz) MAP65 upp till 90 KHz bandbred

The screenshot shows the MAP65 software interface with the following components:

- Frequency List:** A table with columns for Freq, DF, Pol, UTC, DT, dB, KV, DS, and TxPol. It lists various stations and their parameters.
- Control Panel:** Includes buttons for Log QSO, Stop, Monitor, Decode, Erase, and Stop Tx. It also features a TX control section with call signs (F6HEO, JN17mm), a frequency set point (73), and a TX mode selector (Tx1 to Tx6).
- Message Log:** A window titled 'Messages' showing a list of received messages with columns for Freq, DF, Pol, UTC, dB, and CQ Only.
- Time Display:** A digital clock showing 06:34:17.

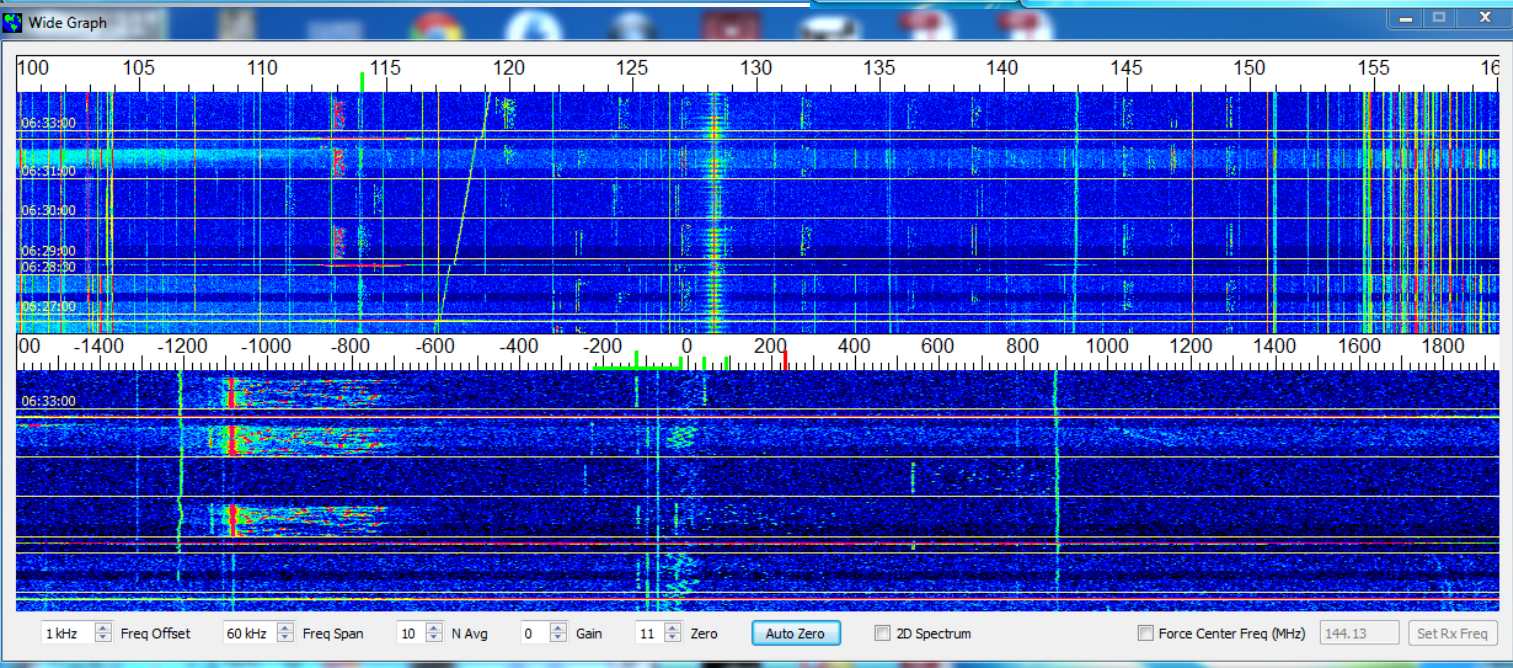

Installing MAP65 and the FUNcube Dongle Pro+ <http://kb5wia.blogspot.se/>

Mitt 23cm äventyr

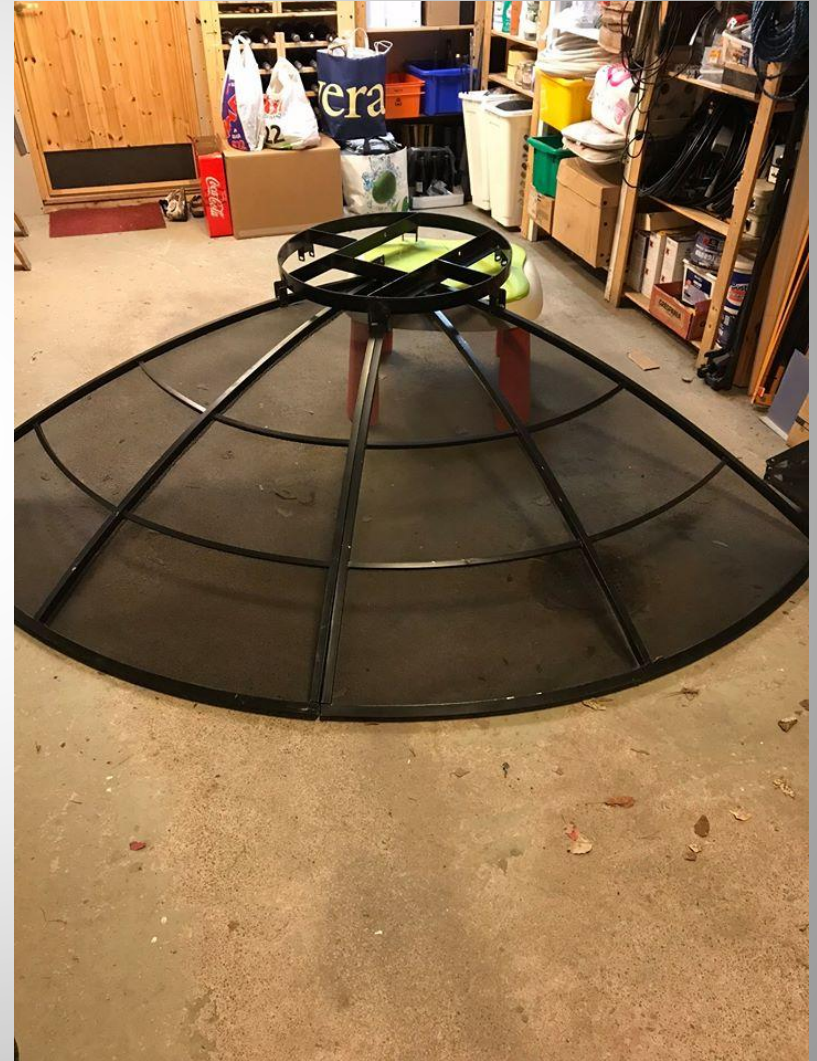

Provmontering och mätning av solbrus



Utökning av storlek 3 m – 3.8 m

Se här för mer info: https://www.sm4ggc.se/onewebmedia/QTC_23cm.pdf

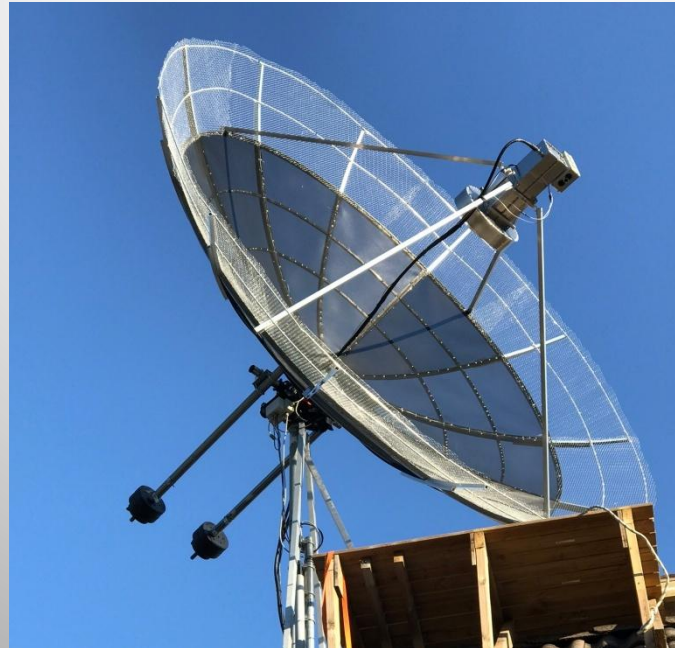

SM4GGC echo 600 W 3.8 m dish

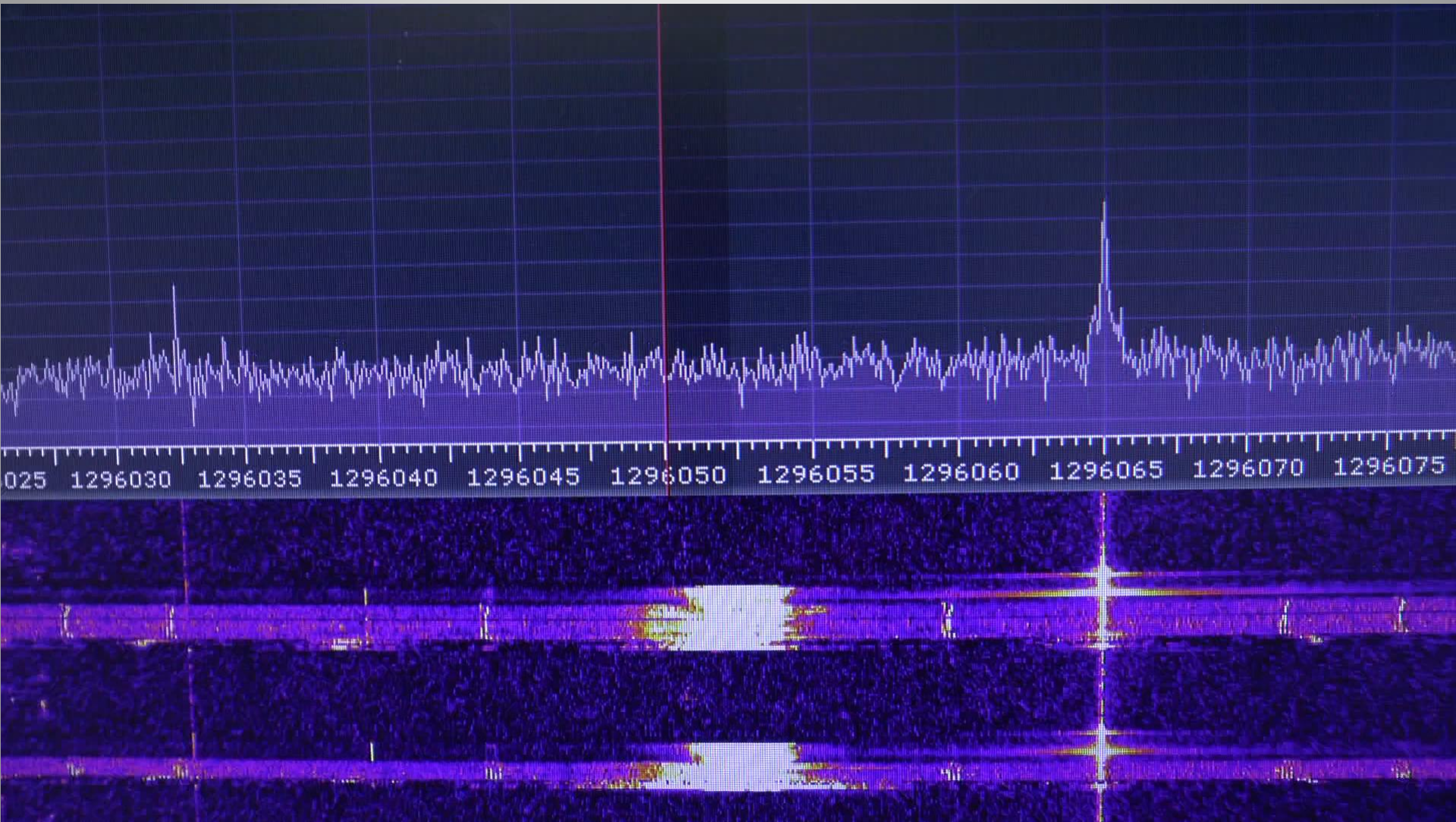

QSO IK1FJI SSB 1 KW 3.2 m dish

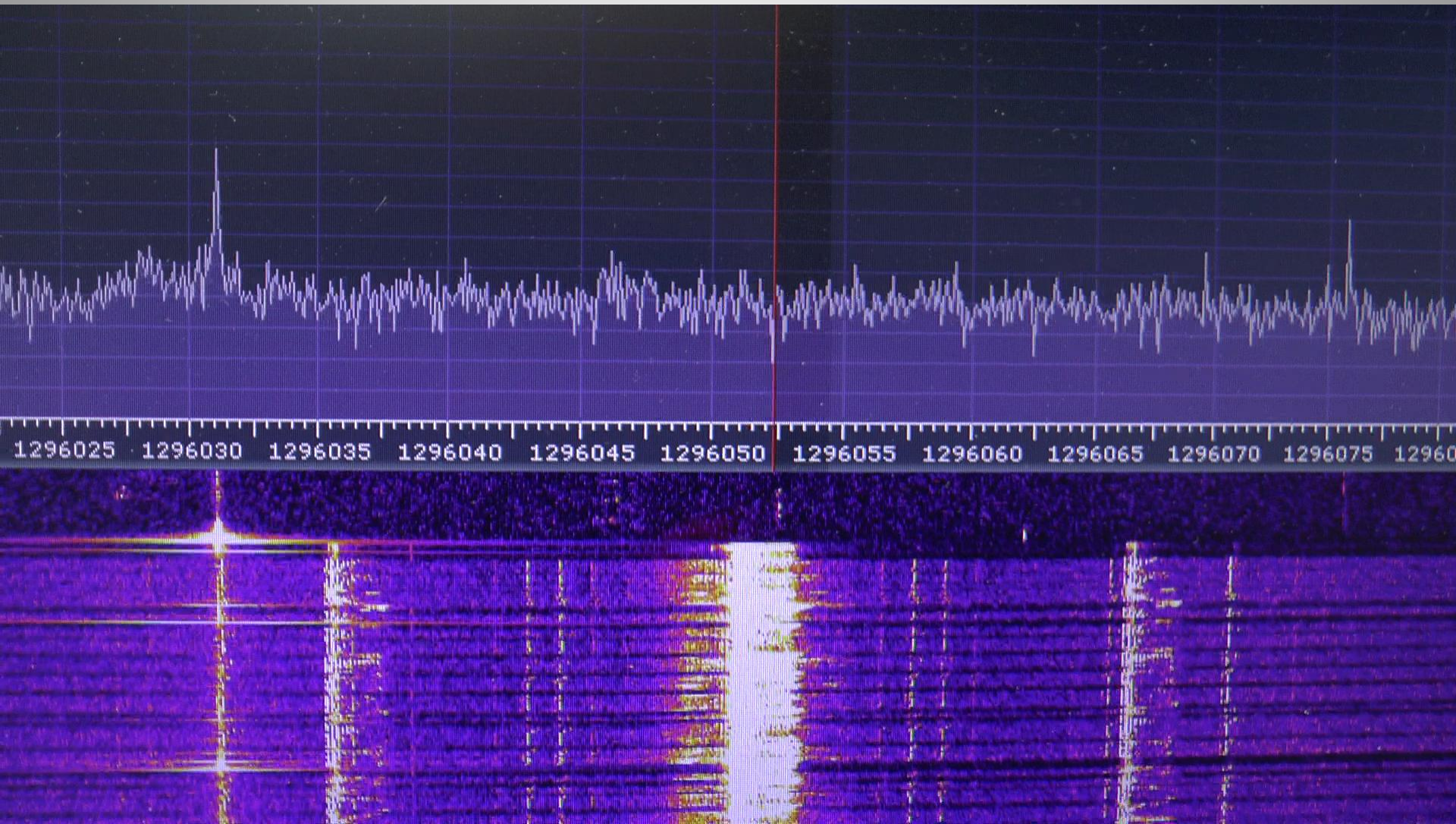

Demonstration av Månstuds av PI9CAM vid EME-conference 2018



Resultat på EME

- EME Initials
- 2 m: 921 st
- 70 cm: 111 st
- 23 cm: 263 st



- På 23 cm
- 101 CW Initials totalt 368 CW QSO och 23 SSB QSO

Meteoritscatter

- Reflektion mot joniserade spår från stenar och grus som faller ned från rymden
- Frekvenser 50 MHz, 144 MHz och (432 MHz)
- Sporadiska meteoriter året om
- Större Meteoritskurar

Perseiderna 10-14 Aug, Geminiderna 12-14 Dec,
Kvadrantiderna 3 Jan, Lyriderna 20-23 April

Virgo

Meteor Sky View

2024-04-23
06:33:00 UTC

Data for location:
jo69rk

Enter your locator:
jo69rk

Sky display

- W - E
- Ticks
- Labels

Azimuth indicator

- Antenna
- Meteor trails
- Only major showers

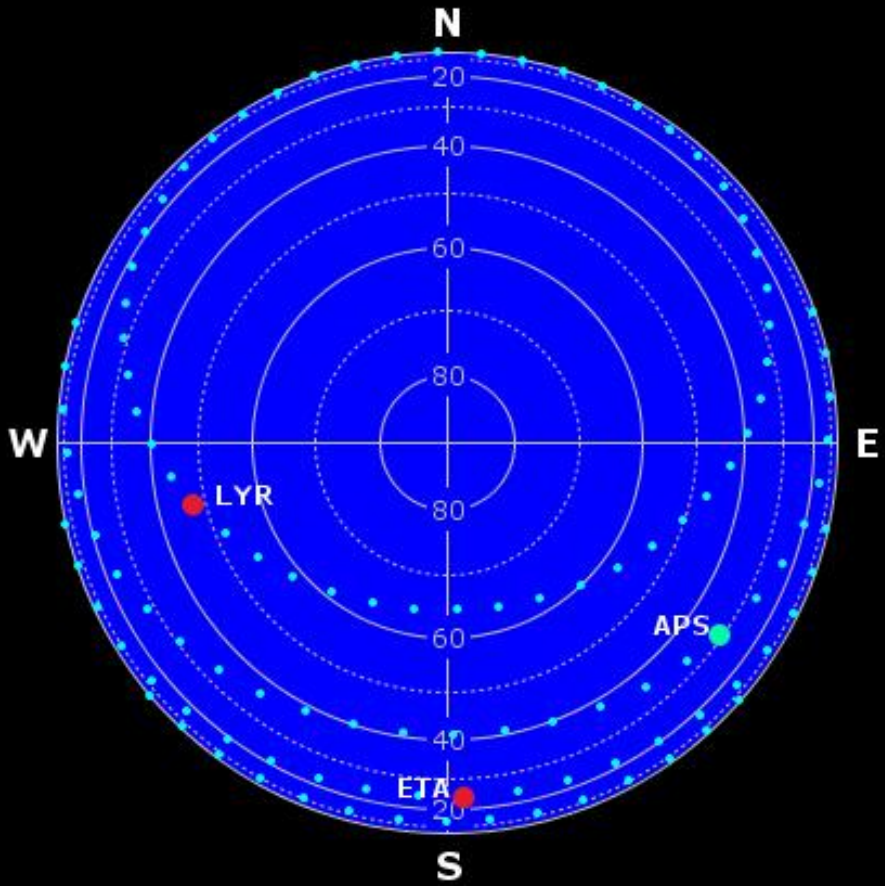

Meteor Shower	Ref.	Rise	Set	RA	Decl.	ZHR	Class	Visual Activity Peak
Lyrids	LYR	circumpolar	01:29	272	34	18	1 ●	2024-04-22 07:17
Eta-Aquarids	ETA	01:20	12:05	326	-6	50	1 ●	2024-05-05 20:48
Antihelion Source	ANT	19:56	04:00	225	-17	4	2 ●	
Pi-Puppids	PPU	not visible		110	-45	var	3 ●	2024-04-23 12:20
April Piscids Daytime	APS	02:13	16:54	9	11	--	4 ●	2024-04-22 11:43

Dyngsvariation av sporadiska meteoror

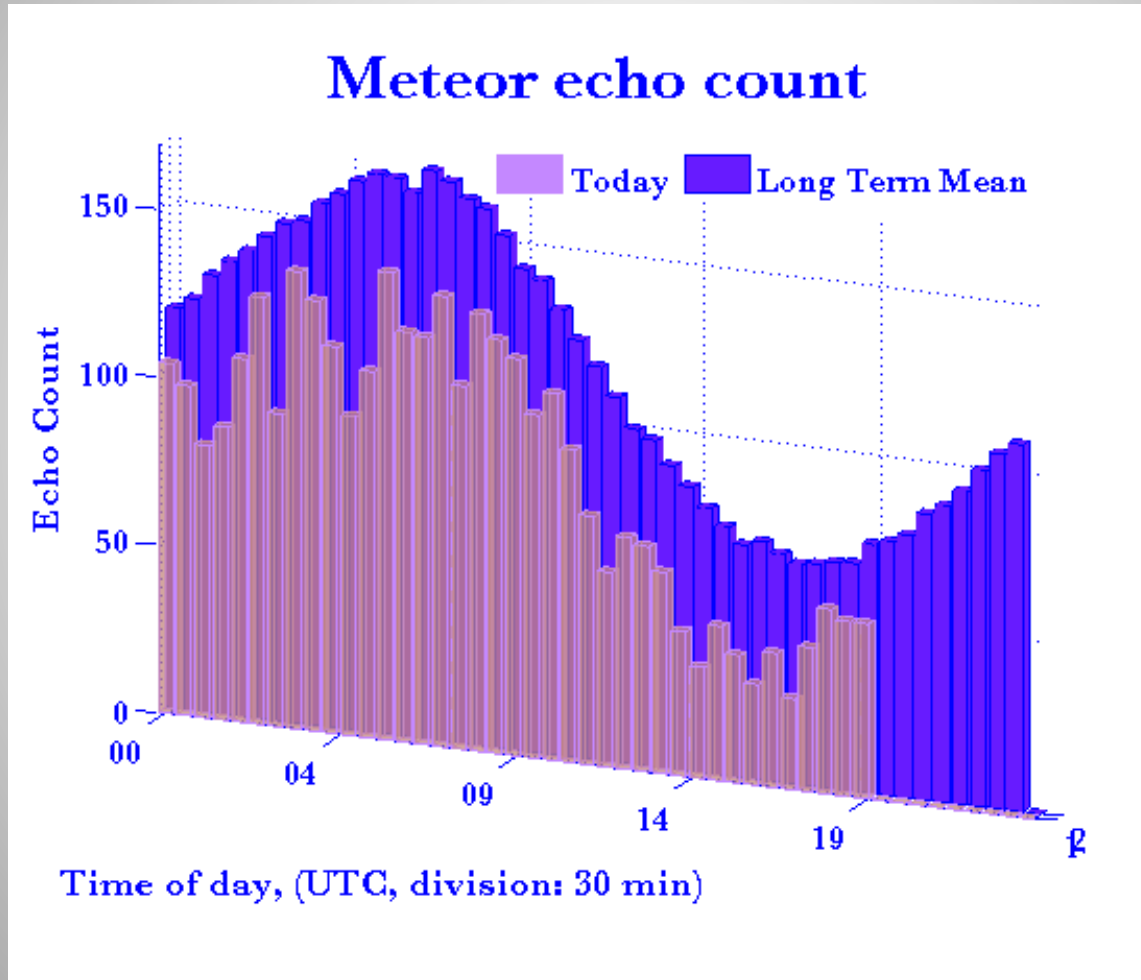

Moder för meteoritscatter

- Hi speed CW 500- 1000 lpm (används knappast längre)
- SSB Jobbigt att genomföra QSO (jag har gjort det)
- Nyare digitala moder
FSK441, JTMS, JT6M, **MSK144**
- Vad ska jag då använda?
Min rekommendation i ordning av mest använda
50 MHz: **MSK144**, (JT6M NAC tester)
144 MHz: **MSK144**, **FSK441**
432 MHz: **FSK441**, MSK144

Vad är största skillnaden mellan de olika ”moderna

- FSK441, JTMS och JT6M: Avkodar tecken för tecken och ingen felrättning i programvara för dessa moder
- MSK144 Avkodar hela meddelanden med inbyggd felrättning

Olika rapportssystem i moderna

- FSK441, JTMS, JT6M och använder IRAU rapportssystem för ett MS QSO

b. Reporting system

The report consists of two numbers:

First number (burst duration)	Second number (signal strength) S-units S/N
2 : up to 0,5 s	6 : below S2 or below 5 dB
3 : 0,5 - 1 s	7 : from S2 to S3 or from 5 dB to 10 dB
4 : 1 - 5 s	8 : from S4 to S5 or from 10 dB to 15 dB
5 : longer than 5 s	9 : above S5 or above 15 dB

Note that the number "1" is not used as the first number/burst duration.

- **MSK144: Rapport här är signalstyrka i dB ex: +08 dB Ingen info om burst duration sänds**

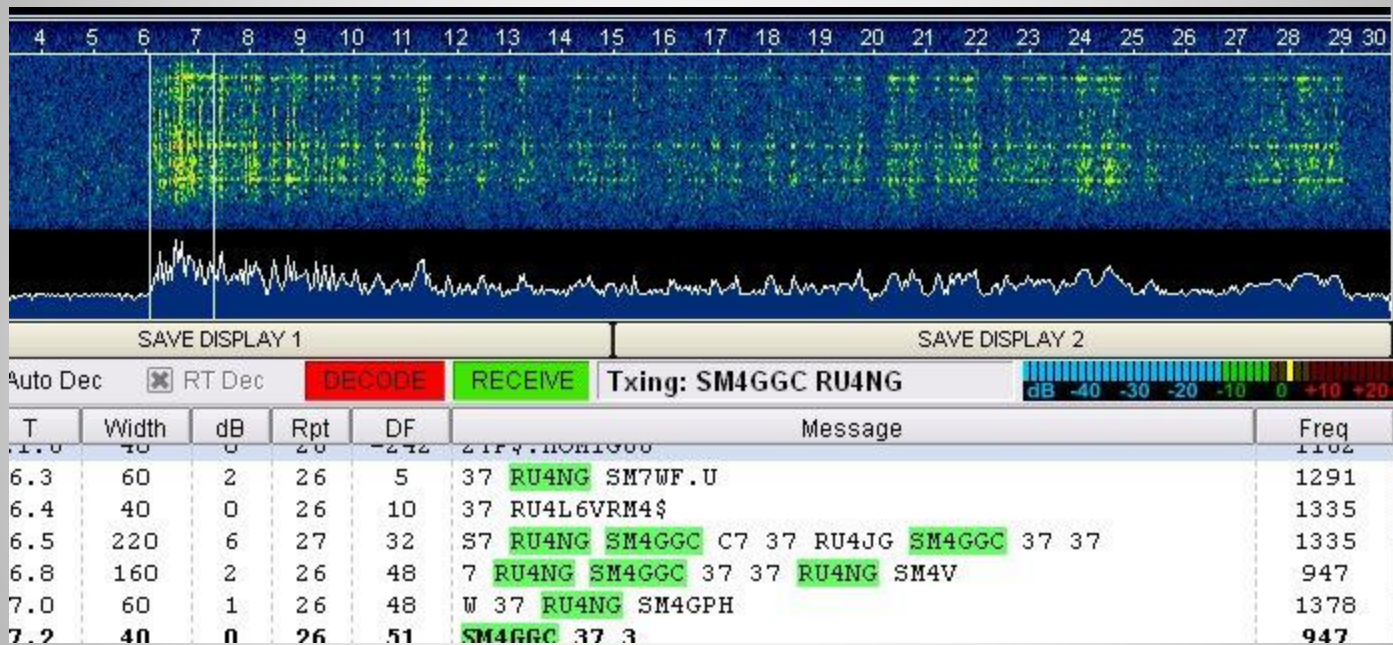

4% CPU3 0% CPU4

TUNE DISPLAYS

SAVE DISPLAY 1 SAVE DISPLAY 2

FSK441 Auto Dec RT Dec DECODE RECEIVE Txing: 73 SM4GGC

Time	T	Width	dB	Rpt	DF	Message	Freq
070730	23.1	200	1	26	-80	KOF 26 26 RA1CW DLOHOF 26 26 RA3W DO	818
070730	23.4	40	0	26	-193	DLOHOF 26 .6E	1981
070730	23.5	40	0	26	-185	6!RA1AW DMOHOD	818
070730	22.6	80	0	26	-99	A1AW DLOHOF 26 26 R\$	1076
070800	28.6	200	4	26	-180	KSU QU2Q 333 I1RJP CQ 3, #I/RFS0\$Y33	1593
070830	24.8	60	0	26	-72	ONX6M/VX KO9	1550
071000	27.7	80	3	26	148	H4B\$? # XFS4B, RD	1894
071030	6.5	120	0	26	-75	1HB4 P K#3B499R944?Q1M0	1162
071030	7.2	200	2	26	-142	9NFQ! **6.E EOB U Q7PTJ6NE*?	1162
071030	7.2	380	2	26	-148	9NFQ! ##8E 7\$ U?Q7PTF6NEE CQ WC!BMT	1162
071030	7.6	360	1	26	-141	7#T*2B61Q \$K. D.6R2#AS?K2?F2CU814 HJVRSPJ6	2067
071030	21.9	60	3	26	-121	U!COQ 3WSCMSZ\$E	1937
071230	2.5	280	5	27	-118	W01!FFAQE CQ 373 F6APE CQ 373 F6APE CQ 3W3NV	2067
071230	2.4	380	6	27	-118	,IW0!FAQE CQ 373 F6APE CQ 373 F6APE CQ 3W3	775
071230	15.9	40	0	26	-72	S TE274#SUIF	1378

START MONITOR STOP MONITOR CLEAR MESSAGES RESET QSO STOP TX TUNE

SM4GGC JO69RK Band 144 MHz

ADD TO LOG TO RADIO: F6APE RX RPT: 26

LOCATOR: IN97QI DB IN97QI LOOKUP ADD

HotA: 210° Azimuth: 220° Elevation: 3° Dist: 1630 km

MONITOR R1: R2:

13 Aug 2017 07:13:27

S Limit def=1 0 dB ZAP

DF Tol def=400 +/- 200 Hz

Sh SWL TX RPT: 36

TX/RX 30 s QRG: 344

RXF TX FIRST TX SECOND

GEN MSG AUTO IS OFF

RX +12

- Tx1 F6APE SM4GGC
- Tx2 F6APE SM4GGC 36 36
- Tx3 F6APE SM4GGC R36 R36
- Tx4 RRRR RRRR SM4GGC
- Tx5 73 SM4GGC
- Tx6 CQ SM4GGC
- Tx7 CQ 344 SM4GGC

-12

QSO på Aurora "Norrskén"



Vad orsakar Aurora



Magnetisk laddad solvind som stör jordens magnetfält vi polerna t.ex från solar flares, corona hål på solen

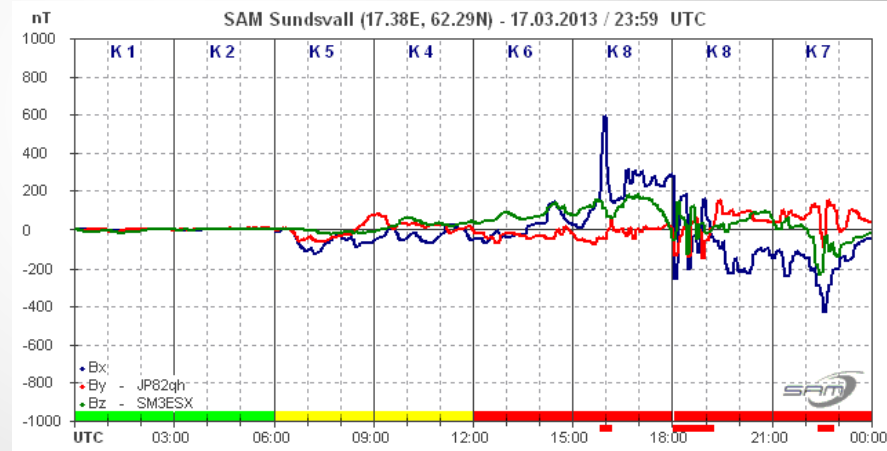
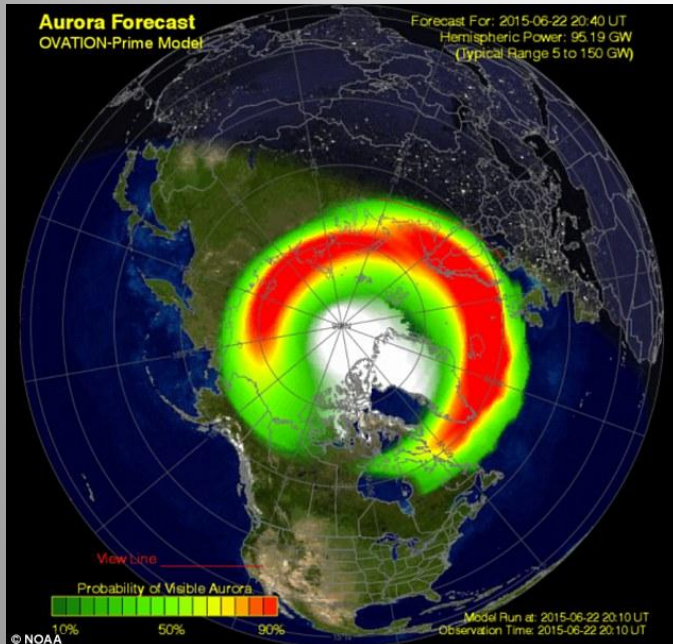

Aurora QSO 50-432 MHz

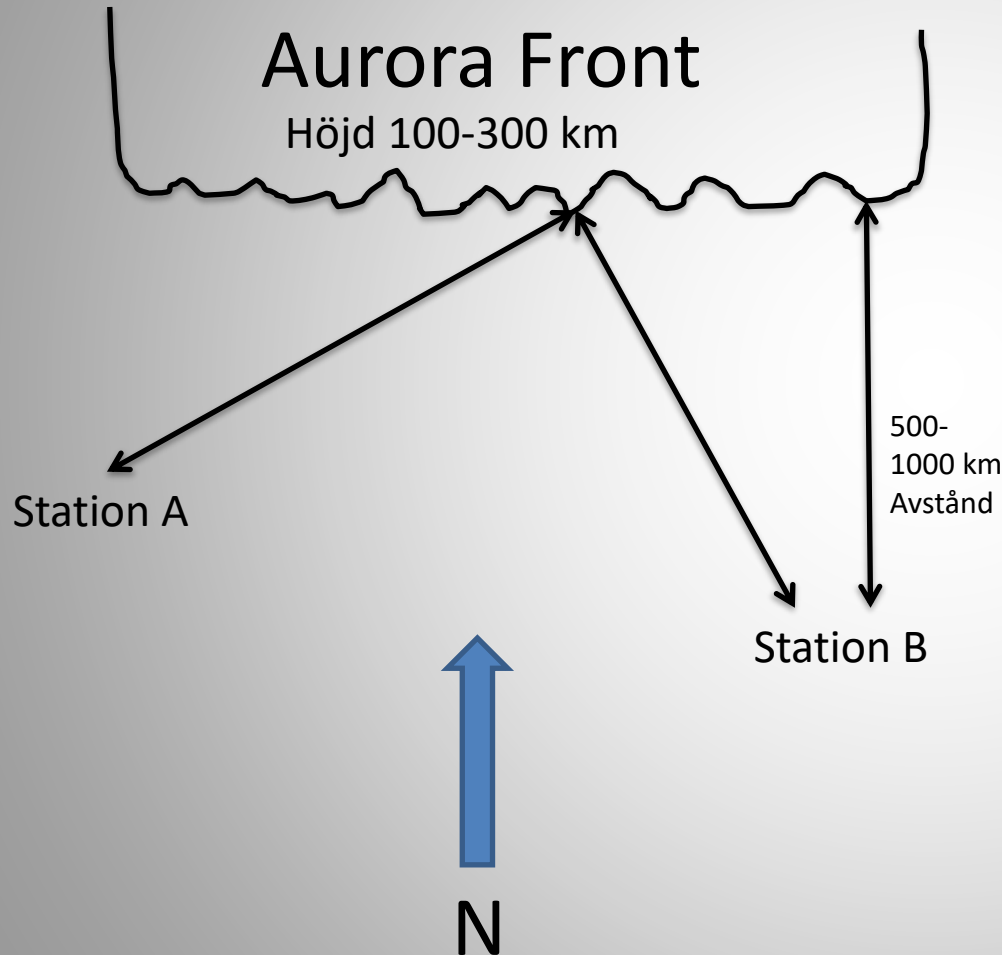

Aurora Fronten flyttar sig ständigt

Antennen får flyttas för max signal Väst till Öst

Aurora fronten är inte homogen som t. ex ett E eller F-skikt.

En liknelse är att tänka sig ett oändligt antal små speglar som signalen reflekteras mot där var och en har sin egen fas

Resultatet blir en icke homogen signal som låter som ett väsende

Dopplerskift på upp till 1 KHz på 144

Signal en kan ändra polarisation

Reflexionspunkter

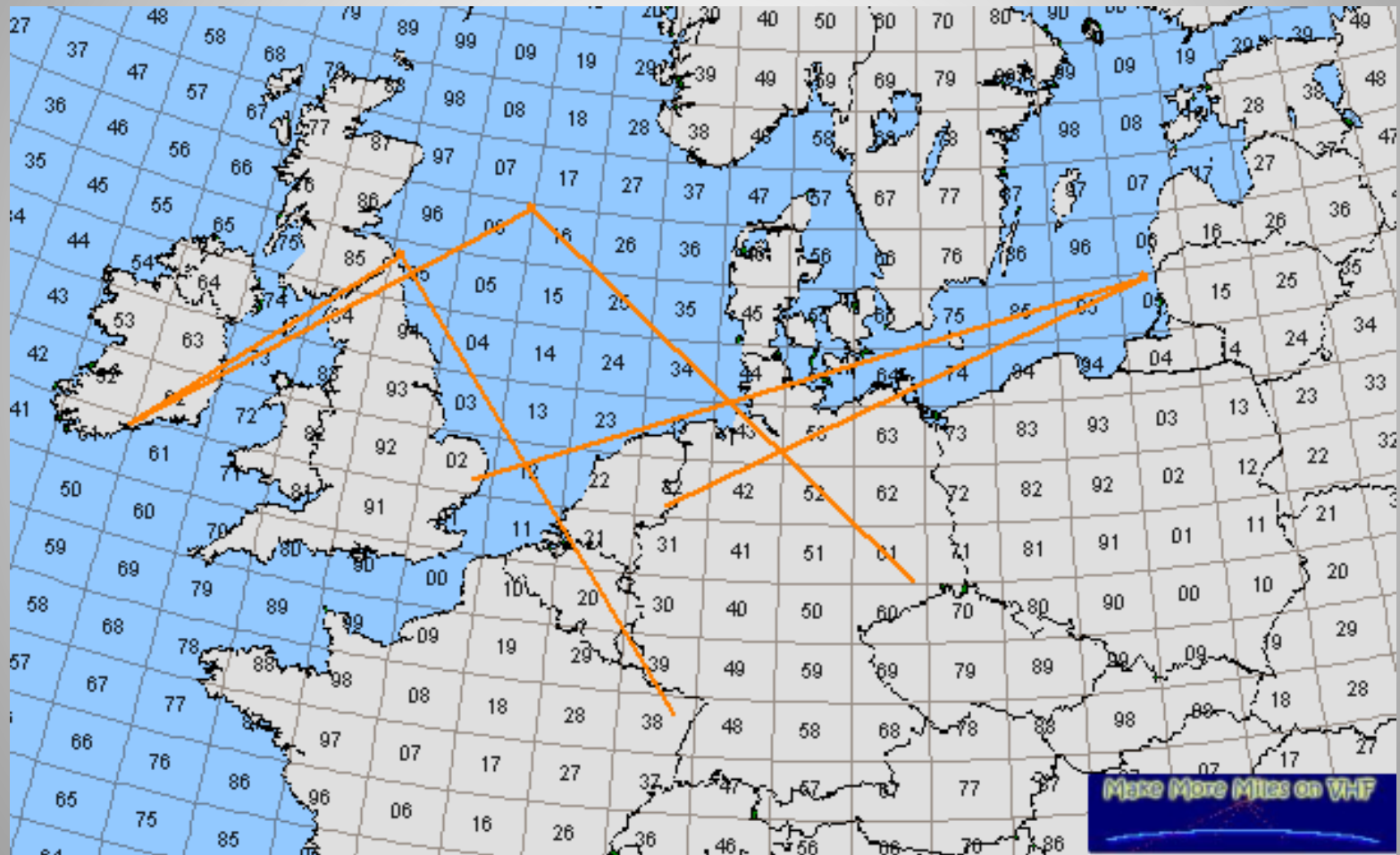

Aurora E eller PMSE? "Polar Mesosphere Summer Echos" på 144 MHz



Optimering vid montering av yagiantenner för olika band i samma mast med hjälp av EZNEC

Påverkan vid vertikal montering av 2 och 70 antenn

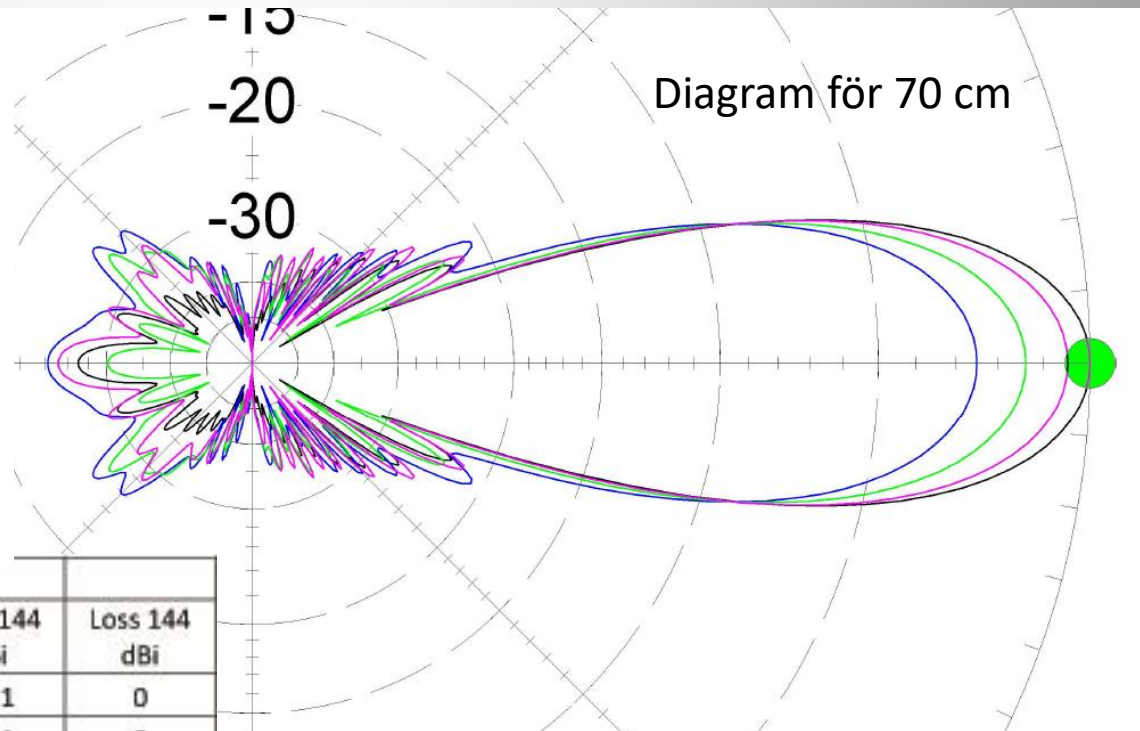
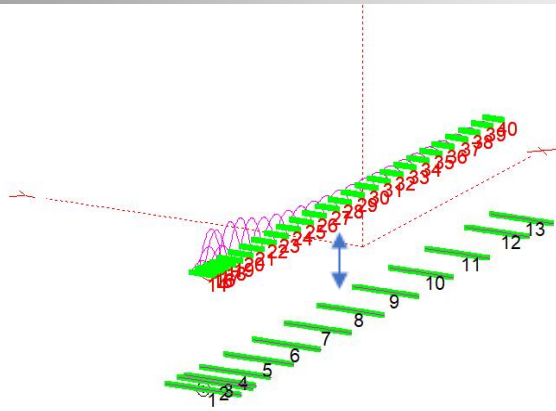

2m 13 el och 70cm 27 el Yagi				
Distance between antennas vertically	Gain 432 dBi	Loss 432 dBi	Gain 144 dBi	Loss 144 dBi
17,5 cm Blue	17	-2,5	16,1	0
35 cm Green	18,1	-1,4	16,1	0
70 cm Purple	19	-0,5	16,1	0
140 cm Black	19,5	0	16,1	0

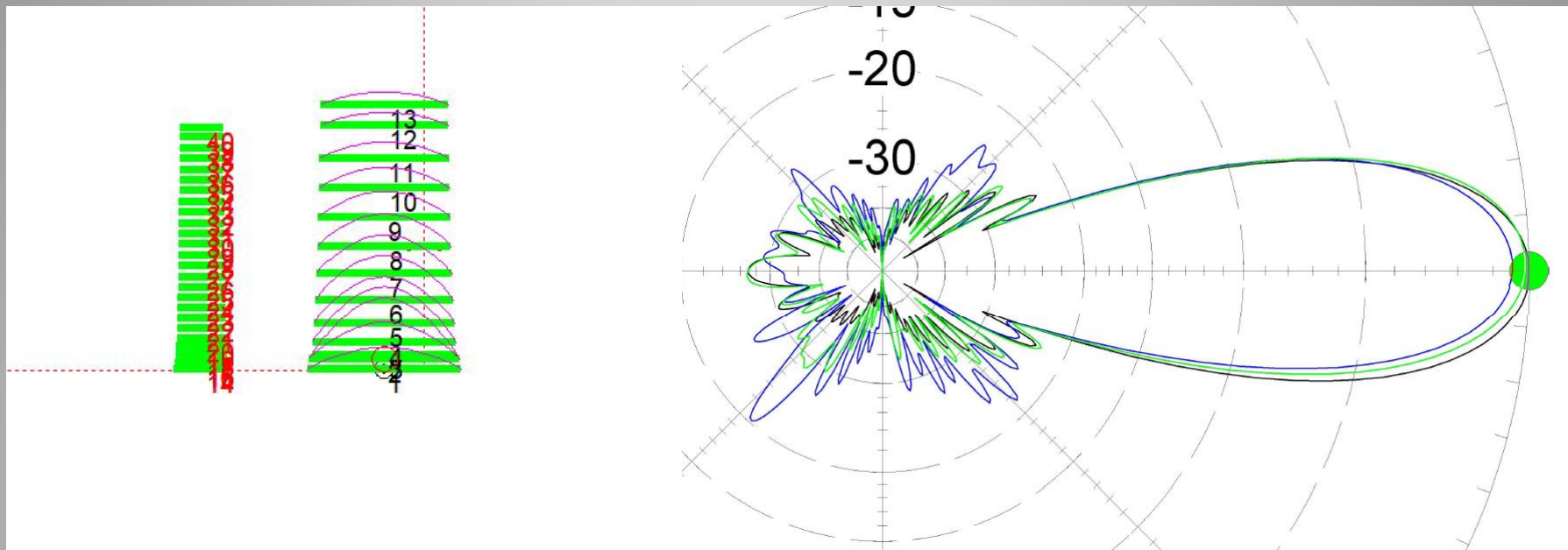

Distance between antenna booms horizontally	Gain 432 dBi	Loss 432 dBi	Gain 144 dBi	Loss 144 dBi
80 cm Blue	19	-0,5	16,1	0
120 cm Green	19,4	-0,1	16,1	0
150 cm Black	19,5	0	16,1	0

Degradation of 2m at distance
between 6m and 2m Yagi

1m=0.61dB

1.5m=0.31dB

2m=0.16dB

2.5m=0.02dB.

Note there is no degradations on 6m

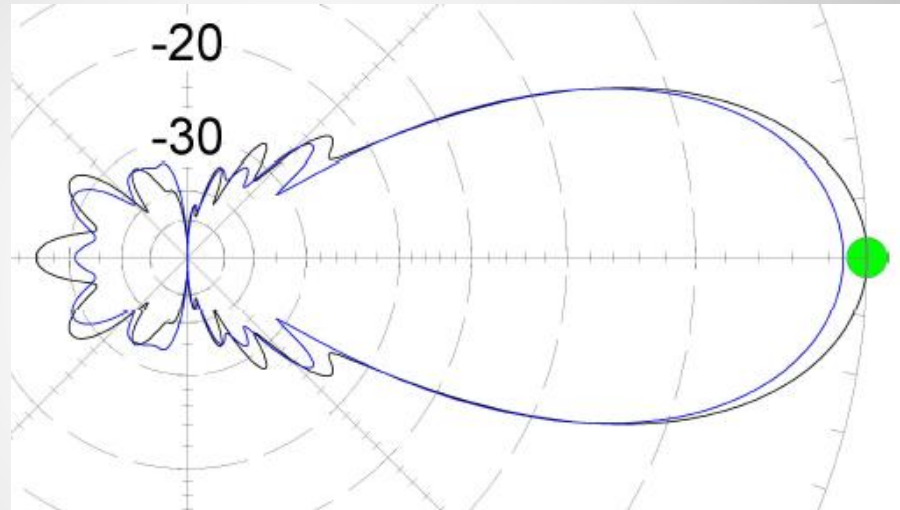
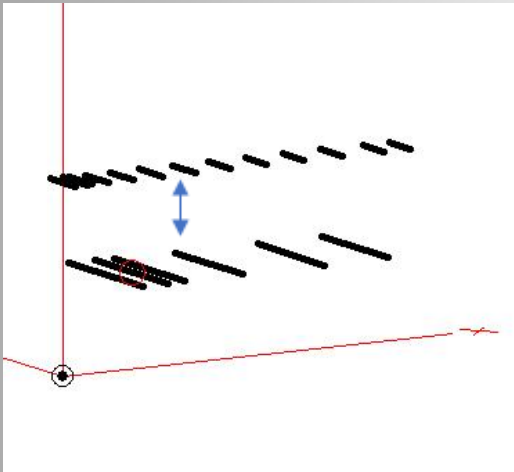



SM4GGC setup 2x5el 6m

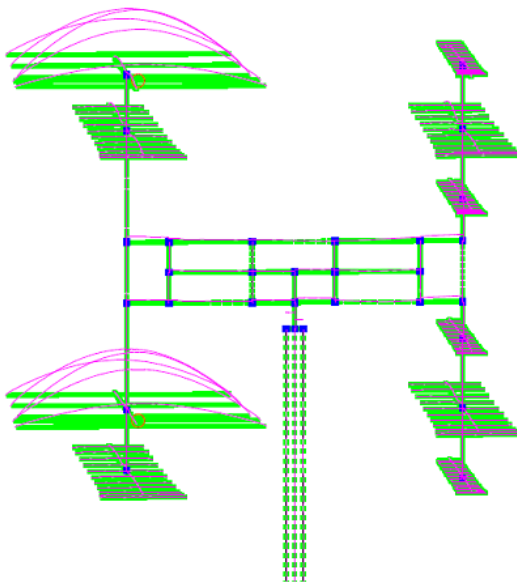

Max Gain 13,06 dBi Beamwidth 46 deg.

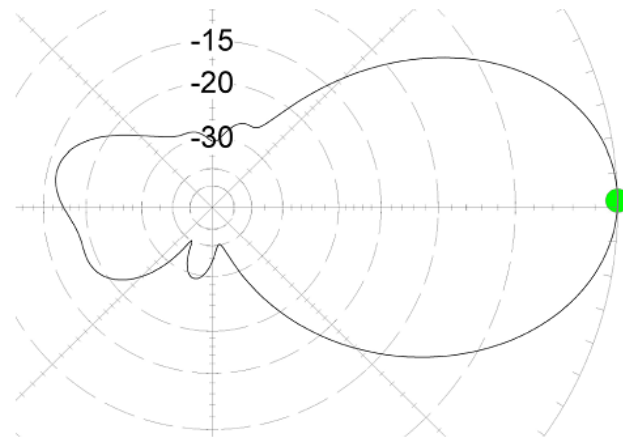

Degradation of gain:

**2m with about -0.5 db,
70cm and 6m have a
couple of tenths**

SM4GGC setup 4x12el 2m

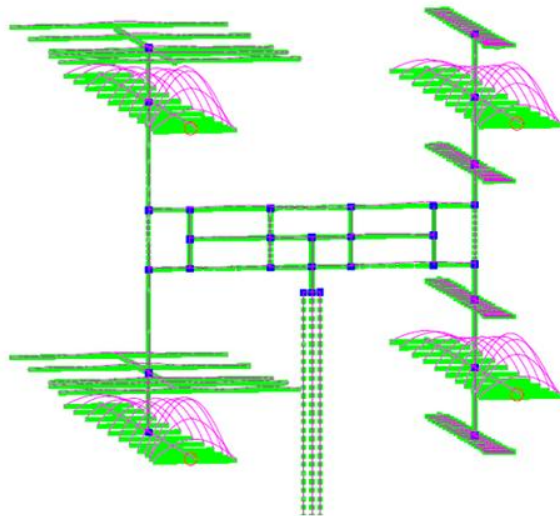

Max Gain 21,14 dBi Beamwidth 13,8 deg

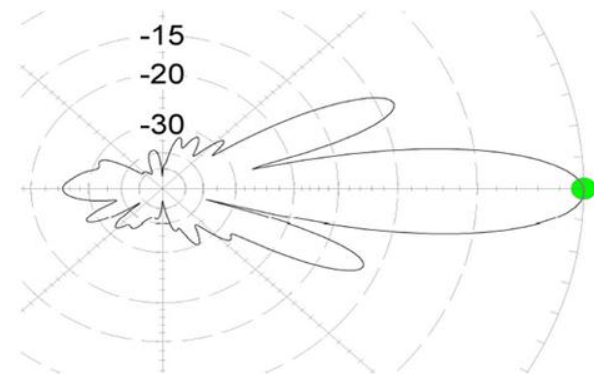

Optimal antennhöjd för 6 m vid ES-förbindelse

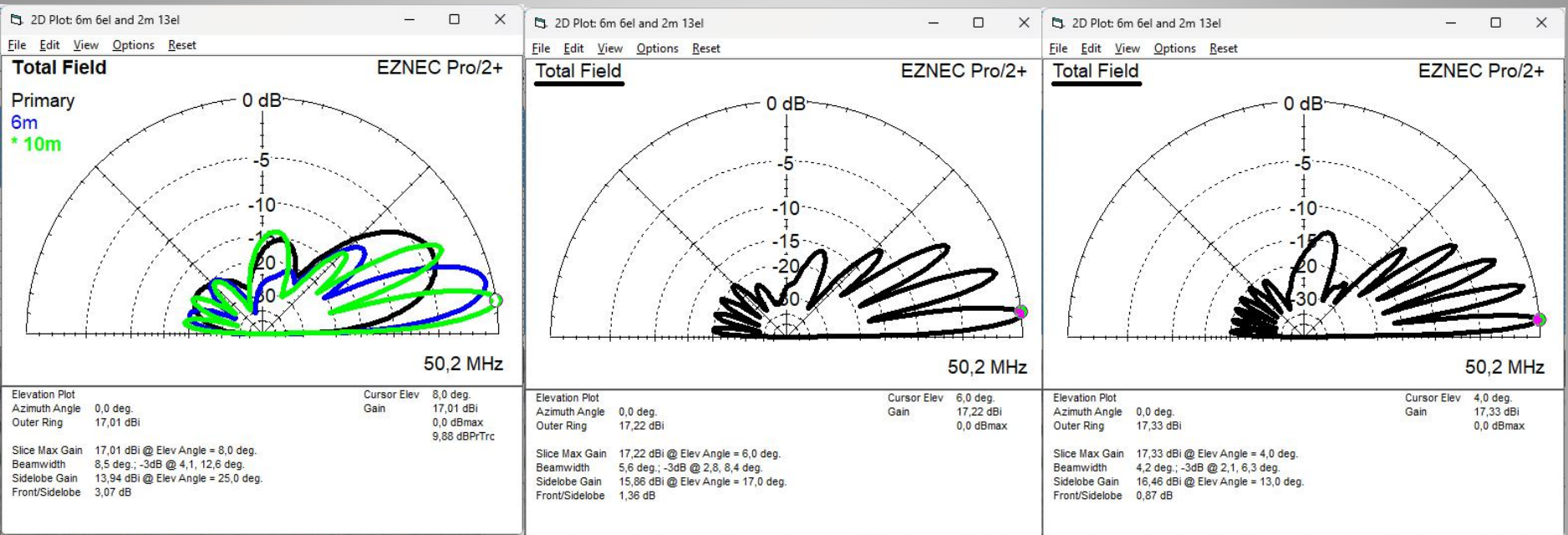

Black = 2m above ground, angle 25 degrees
 Blue = 5 m above ground angle 15 degrees
 Green = 10 m above ground, angle 8 degrees

15 m above ground, angle 6 degrees
 Optimal angle for ES jump 1400 km to
 1600 km is about 6-4 degrees

20 m above ground, angle 4 degrees
 At higher altitudes, the number of flaps
 increases and the elevation appears to level
 off at 2 degrees

Tack för intresset!

